

WCB Circuit Breakers with Auxiliary Switches

APPLICATIONS

- Auxiliary switch monitors the status of the breaker contacts i.e. "On" or "Off"
- Trip alarm switch monitors the tripping of a Circuit Breaker

FEATURES

- Alarm and/or trip alarm switch available in a compact 6.5mm module
- Visual indication of tripping via mid trip handle
- Easy Wiring via quick connect terminals
- Ability to reset the trip alarm without closing the Circuit Breaker



*UL 1077 approval available 01/01/2004

TECHNICAL DATA

Auxiliary Switch / Trip Alarm Switch		
Approvals	UL489	IEC 60947-5-1
Number of change over contact	1 (NO / NC)	1 (NO / NC)
Maximum Voltage	250 V AC	250 V AC
	80 V DC	110 V DC
Maximum Current Rating	6 A @ 250 V AC	6 A @ 250 V AC
	0.5 A @ 80 V DC	0.5 A @ 110 V DC
Interrupting capacity	-	1 kA Aux. Switch only
Number of operations	10 000	10 000
Operating Temperature Range	-5°C TO +40°C	

Ordering:

UL 1099 series

Part No.	Description
WCB-1P-(2 or 9)-X fitted with Aux. switch	1 pole circuit breaker with Aux. switch (X= 1-60 Amps)
WCB-2P-(2 or 9)-X fitted with Aux. switch	2 pole circuit breaker with Aux. switch (X= 1-60 Amps)
WCB-3P-(2 or 9)-X fitted with Aux. switch	3 pole circuit breaker with Aux. switch (X= 1-60 Amps)

UL 489

Part No.	Description
WCB-1P-KM-X fitted with Aux. switch	1 pole circuit breaker with Aux. switch (X= 1-25 Amps)
WCB-2P-KM-X fitted with Aux. switch	2 pole circuit breaker with Aux. switch (X= 1-25 Amps)

DC Circuit breakers

Part No.	Description
WCB-1P-U2-DC-X fitted with Aux. switch	1 pole circuit breaker with Aux. switch (X= 1-50 Amps)

Technical Data

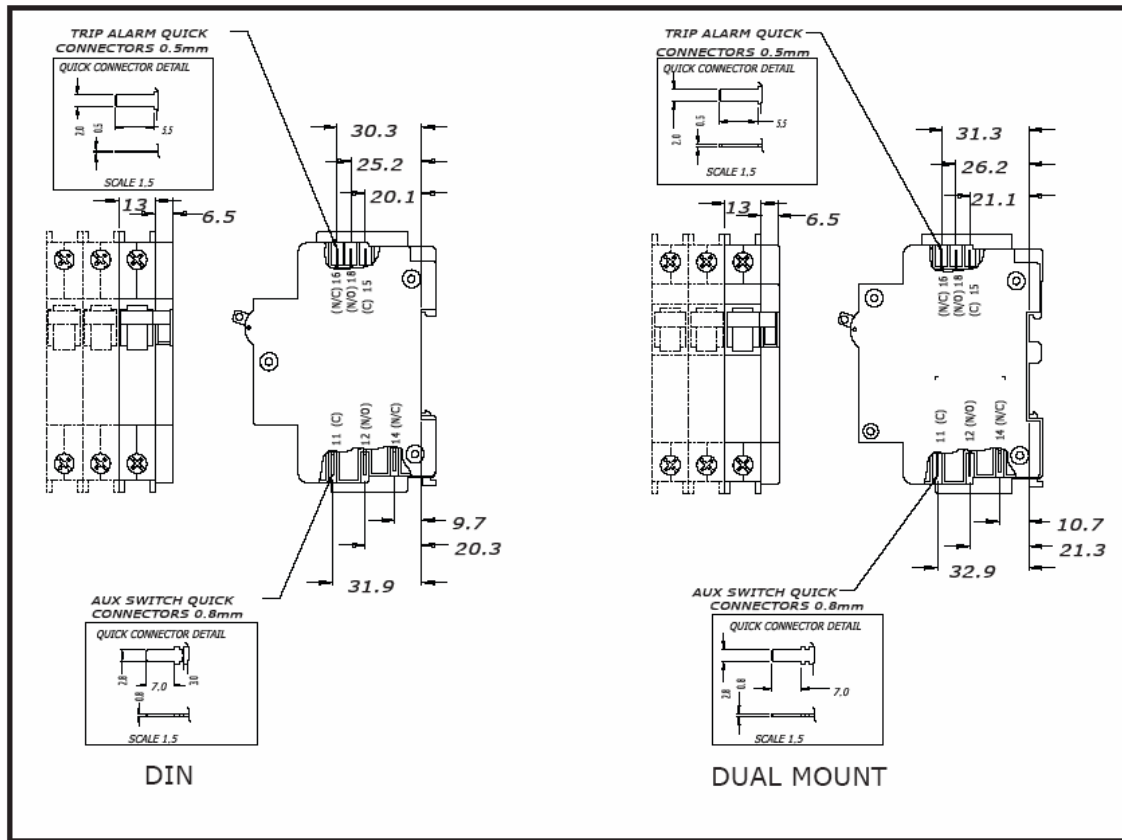

Ordering:

UL 1099 series

Part No.	Description
WCB-1P-(2 or 9)-X fitted with Aux. switch	1 pole circuit breaker with Aux. switch (X= 1-60 Amps)
WCB-2P-(2 or 9)-X fitted with Aux. switch	2 pole circuit breaker with Aux. switch (X= 1-60 Amps)
WCB-3P-(2 or 9)-X fitted with Aux. switch	3 pole circuit breaker with Aux. switch (X= 1-60 Amps)

UL 489

Part No.	Description
WCB-1P-KM-X fitted with Aux. switch	1 pole circuit breaker with Aux. switch (X= 1-25 Amps)
WCB-2P-KM-X fitted with Aux. switch	2 pole circuit breaker with Aux. switch (X= 1-25 Amps)

DC Circuit breakers

Part No.	Description
WCB-1P-U2-DC-X fitted with Aux. switch	1 pole circuit breaker with Aux. switch (X= 1-50 Amps)